

INSTALLATION SHEET FOR THE *UNBREAKABOW* 918-202-6128

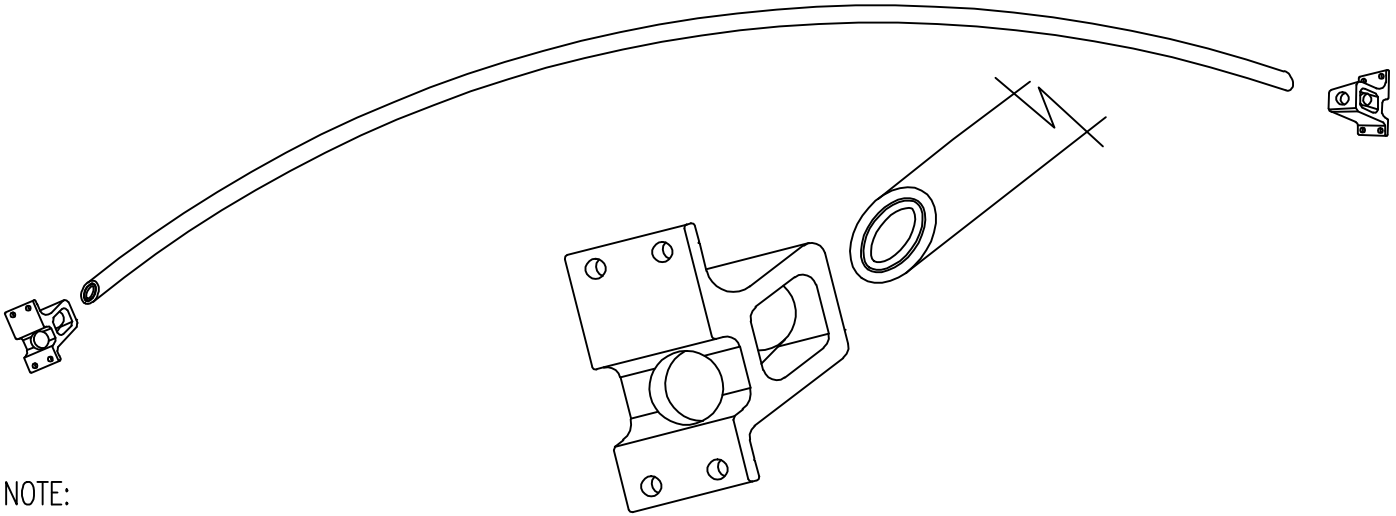

NOTE:

- * NEVER USE A TARP RIDGE STRAP OR RIDGE POLE FRONT TO BACK WHEN USING THE *UNBREAKABOW*.
- * NEVER EXCEED 48" CENTERS ON BOW SPACING.
- * *UNBREAKABRACKETS* MUST BE USED WHEN INSTALLING THE *UNBREAKABOW*.

STEP 1:

- * EQUALLY SPACE BOW BLOCKS ON EACH SIDE OF TRAILER.
- * MOUNT BOW BRACKETS FLUSH WITH TOP RAIL.
- * WELD TOP AND BOTTOM.

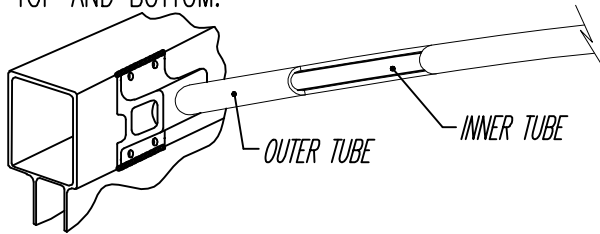

STEP 4:

NOTE: TRAILER WIDTH MAY VARY FROM FRONT TO BACK. TO MAINTAIN 11" TO 14" ARCH, MEASURE TRAILER WIDTH AT EACH BOW LOCATION.

(OPTIONAL) IF USING BOW BRACKETS, SLIDE BOW INTO SOCKET AND TRIM IF NECESSARY.

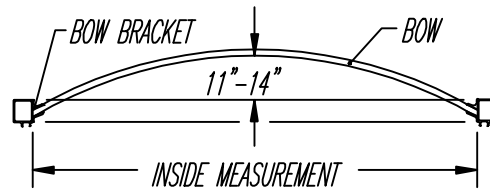

STEP 2:

- * CUT BOW ENDS AT 25° ANGLE TO OBTAIN 11" TO 14" ARCH.
- * CUT SHORT SIDE OF BOWS 5" LONGER THAN INSIDE TRAILER WIDTH. (SEE BELOW)



EXAMPLE: IF TRAILER WIDTH IS 90" INSIDE TO INSIDE, CUT SHORT SIDE OF BOW 95" LONG.

STEP 3:

- * CUT INSIDE AND OUTSIDE TUBES SEPARATELY - INSIDE TUBE WILL ROLL IF CUT TOGETHER WITH OUTER TUBE.
- * CUT LONG! YOU CAN ALWAYS CUT AGAIN!

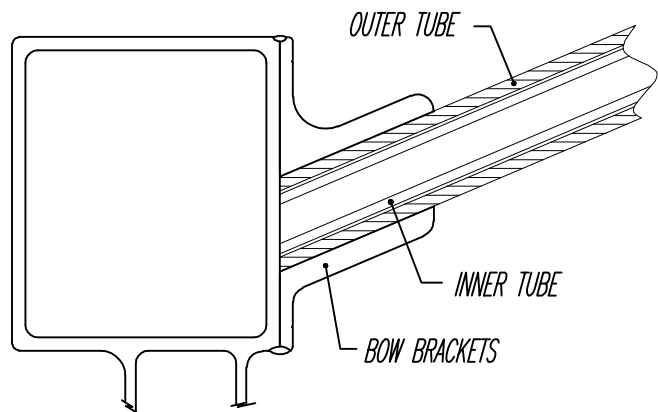

~~~~~  
NORMAL OPERATING TEMPERATURE FOR THESE BOWS IS 10° F-160° F MAX.